

Lubricate all seals with clean hydraulic fluid, prior to assembly.
Do not use silicone based lubricants.

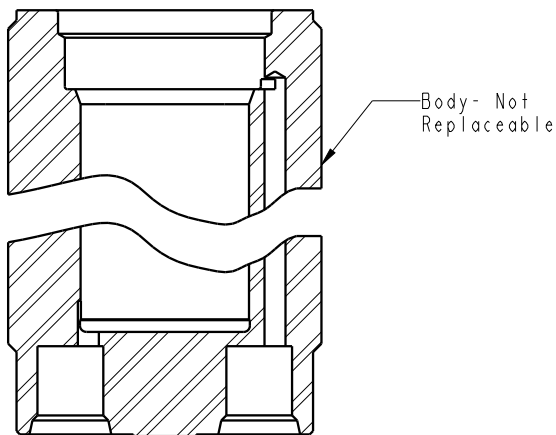
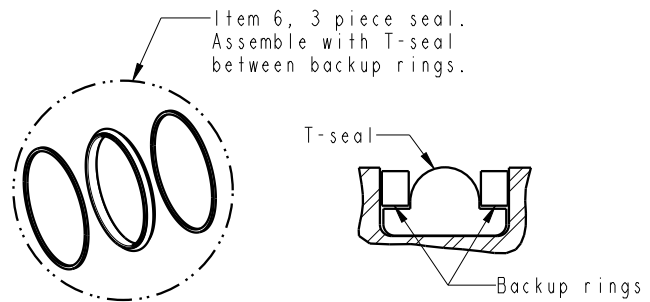
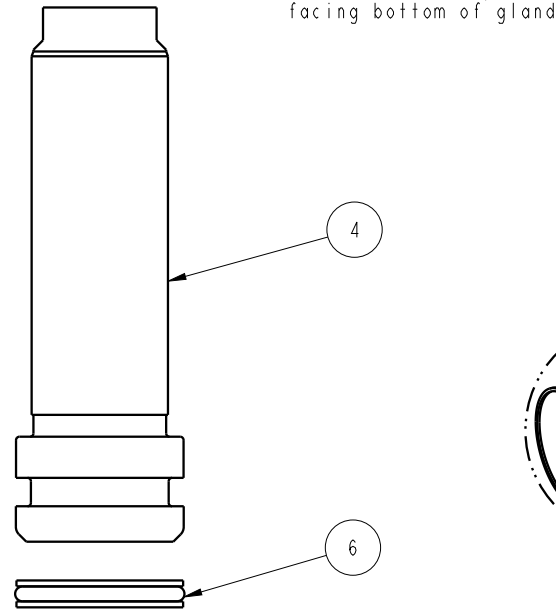
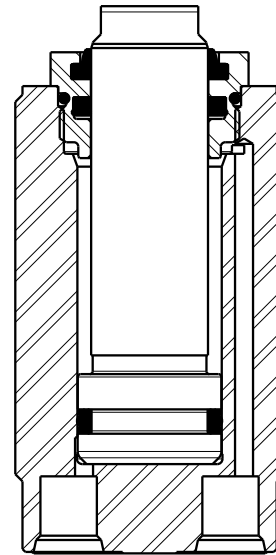
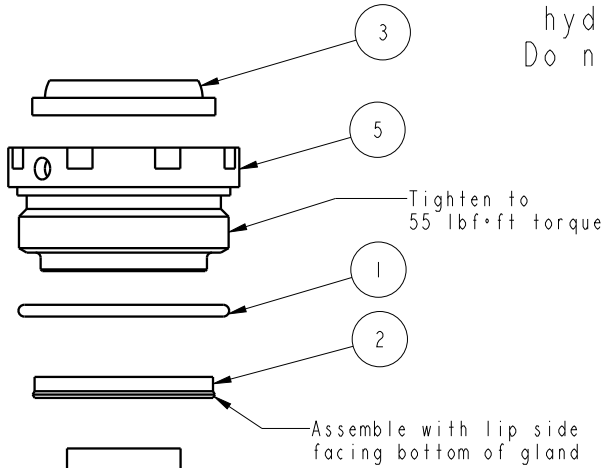

Standard Seal Kit	Fluorocarbon Seal Kit
60-2002-10	6V-2002-09
39-H100-17	39-V100-17
39-0110-45	39-0120-05
39-0010-11	39-0120-13
39-0120-08	39-0120-08

No.	QTY	PART No.	DESCRIPTION
6	1	39H10017	SEAL, T, (13/16 X 5/32 X 1)
5	1	82031002	GLAND, CYL, 3900 & 17.8 KN
4	1	82011007	PISTON, CYL, 3900, 1.5 STRK
3	1	39012008	WIPER, SNAP-IN, (13/16)
2	1	39011045	SEAL, LL, (13/16 X 1/8 X 1/8 X 1-1/16)
1	1	39001011	O-RING, (-024)

PARTS LIST



VEKTEK, INC.
1334 E. SIXTH AVE. P.O. BOX 625
EMPORIA, KS. 66801 U.S.A.

Model Number
20-0210-04
20-0210-04F

ASSY, CYL, TB, 3900, 1.5 STRK, DA

SIZE
A

PL2125

REV
G

SHEET 1 OF 1

G	5499	RELEASE	NPETERS	9/23/24
REV	IN ACCORDANCE WITH ECN	EFFECTIVE DATE	REVISED BY	DATE
DRW BY:	JACOB	DRAWING STATUS: Released		
DATE:	9/20/96	PRODUCTION APPROVED FOR RELEASED STATUS ONLY		

FORM FEG035_PL_ASIZE, REV. B